



Datamarine®
Precision Marine Instruments

OWNERS MANUAL FOR THE
CORINTHIAN SERIES
LX-360
“wind machine”

INTRODUCTION

Datamarine is pleased you have chosen our LX-360 "Wind Machine" for installation on your sailboat. This instrument is the most modern and reliable wind instrument available and will give you many years of uninterrupted sailing pleasure.

2

The LX-360 provides both wind direction (in 360° analog form) and wind speed (in digital form) information in one compact, watertight, 4" aluminum case. Provision has been made for an additional indicating unit or a close hauled indicator to be added either now or at a later date.

Take a few minutes to read through this short installation and operation manual to familiarize yourself with your new LX-360 and the advantages it provides to the serious sailor.



GENERAL DESCRIPTION

The Model LX-360 apparent wind/wind speed indicator is an advanced design, wind instrument giving a sailor all the wind information needed on one, compact instrument. Wind direction information is displayed in analog (pointer) form on a front panel meter covering a continuous, full 360°. Wind speed information is displayed digitally, in knots, on a two digit liquid crystal display. The entire face is lighted for night operation.

- 4 The LX-360 is supplied with 80 feet of mast wiring, a mast step junction box, and all necessary masthead material. Cable length is not critical and may be lengthened or shortened as needed.

Internal, lower unit, adjustment (up to $\pm 180^\circ$) is available in the LX-360 to compensate for any mounting angle of the masthead unit. This eliminates the need for exact fore/aft positioning of the wind vane.

Provision has also been made for the use of a remote unit for the LX-360. A description of remote installation will be found in the section entitled "Remotes."

SPECIFICATIONS

Masthead Unit

- Weight:** 12 ounces
- Direction Transducer:** Synchro transmitter driven by a balanced wind vane. Hydraulically damped.
- Speed Transducer:** Hall effect device triggered by a rotating magnet, driven by a three-cup anemometer.

5

Indicator Unit

- Size:** 4" anodized aluminum housing
- Direction Indicator:** Synchro receiver, continuous 360° display
- Wind Speed Indicator:** 2-digit (00 to 99 knots), liquid crystal display, 1/2" high

GENERAL SPECIFICATIONS

- Accuracy, Direction:** Indicator will track vane within $\pm 1^\circ$ at 5 knots, lubber line accuracy determined by alignment of indicator during installation. $\pm 180^\circ$ of correction is available, at indicator unit, to compensate for masthead misalignment.
- Accuracy, Speed:** ± 1 knot (calibrated at 15 knots)
- Power Requirements:** 11 - 16 volts D.C. (12 volt battery system)
- Current Drain:** 100ma nominal @ 12VDC, 250ma max. @ 12VDC with lighting
- Repeaters:** Provision for one repeater with no decrease in specified accuracy provided. Direction alignment must be matched to master unit.
- Cabling Requirements:** 6 conductors plus shield
- Temperature Range:** Operating, 10°F to 175°F Storage, -40°F to 175°F
NOTE: The display will be readable at temperatures between 10°F and 175°F .

NOTE: Care should be taken to store the masthead unit right-side-up (wind vane on top, wind cups on bottom) during winter lay-up.

OPERATION:

After installation and alignment (if necessary, see section entitled "Alignment") your LX-360 is totally automatic in operation. The only control is for OFF-DAY-NIGHT lighting and is located on the rear panel (see figure 1).

On the rear panel, one will note the following:

OFF-DAY-NIGHT Switch: Used for control of the instrument.

OFF denotes no power to the instrument or the masthead unit. **DAY** turns the LX-360 on for daylight viewing. **NIGHT** illuminates the instrument for night operation. Power drain is minimal in the day mode.

POWER: 12VDC (0.1 ampere) connected with in-line 1 amp fuse to ship's battery. Power connections are available for remotely mounted OFF-DAY-NIGHT brightness control.

INPUT: 8-pin connector for masthead wir-

ing. This provides all connections necessary for wind speed and wind direction sensors.

When the instrument is operating, there may be a slight hum heard from the LX-360. This is normal and should be expected.

As one sails with the LX-360, the instrument will give continuous apparent wind angle readings with relation to the lubber (fore and aft) line of the boat. The meter (being full 360°) will pass through 0° when tacking and through 180° when jibing. The digital wind speed display will indicate apparent wind speed under all operating circumstances.

The front panel of your LX-360 is scratch resistant and the housing has an anodized finish. You may clean and wipe the face panel as you would other parts of the boat, using a mild soap and water as necessary (highly abrasive cleaners are not recommended). Do not, however, spray the rear panel connections.

Figure 1
LX-360
REAR PANEL VIEW

8

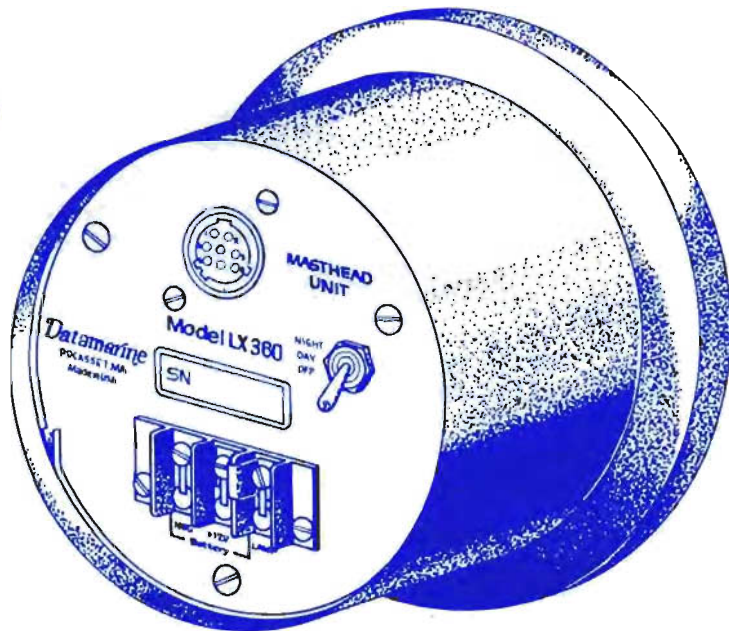

The liquid crystal display of your new instrument has been thoroughly tested and manufactured for the marine environment. Under extreme temperatures, however, the display will become unreadable. Extreme heat (above 175°F) will tend to black out the display, (display will become operational again when temperature is reduced) while extreme cold (below 10°F) will slow the digits to a point where they will "freeze" on one number. This is normal and should be expected by the new owner. As noted in the specifications, storage temperatures are higher and lower than the above mentioned operation temperatures, however, temperature extremes beyond these specified *can destroy* the liquid crystal display and void the warranty.

In normal operation a small amount of heat will be generated by the night lighting of the LX-360. This will not harm the instrument and may be desirable even in daylight while operating in colder temperatures.

Your LX-360 has a front panel cover to help protect the face and the liquid crystal display when the instrument is not in use. This protective cover should be used whenever your boat is left for a period of time or when conditions warrant further instrument protection.

INSTALLATION

9

The LX-360 is intended to be permanently installed in a cockpit bulkhead or instrument console. It will be watertight and theft proof when properly installed. Select a location on a flat surface which is easily seen by the helmsman while in his normal steering position.

Saw a 4½" diameter hole in the panel for clearance of the instrument's body.

Remove the clamp ring from the instrument. Apply a small amount of waterproof bedding compound around the outer edge of the hole and press the instrument into place. Make sure the 0° and 180° markings line up vertically.

10 Next, place the clamp ring on the LX-360's body, from the inside, and press against the bulkhead or console. Tighten the set screws to the instrument, then the set screws against the mounting panel, to hold the LX-360 in place (see figure 2).

Service of the instrument may be accomplished by removing the "spring retaining ring" from the rear panel and sliding the electronics package out through the back of the instrument. This eliminates the need to break the instrument's waterproof seal.

POWER CONNECTION

The 12 volt d.c. power for the LX-360 should be connected using the power cord provided. The RED lead goes from the +12 terminal to the ship's POS (+) power and the BLACK lead is connected from the "NEG" terminal to the ship's NEG (-) power. The LX-360 is protected against polarity reversal. The instrument's power cord is fused with a 3AG-1 1 ampere fuse. Do not use any other size fuse. (See wiring diagram in figure 3.) The "lamp" terminal (which is jumped to the 12 v terminal) is only used when the accessory remote lighting control (A-180) is connected.

Note that your LX-360 is designed and warranted for operation on 12 volt battery systems only. Excess voltage can seriously damage the instrument and void the warranty.

Figure 2
**BULKHEAD MOUNTING
OF LX-360**

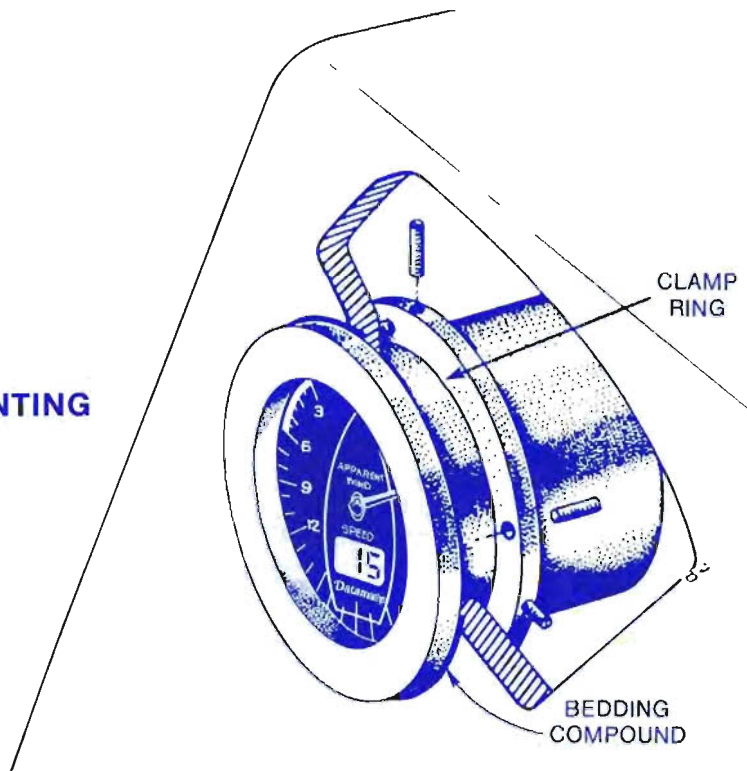
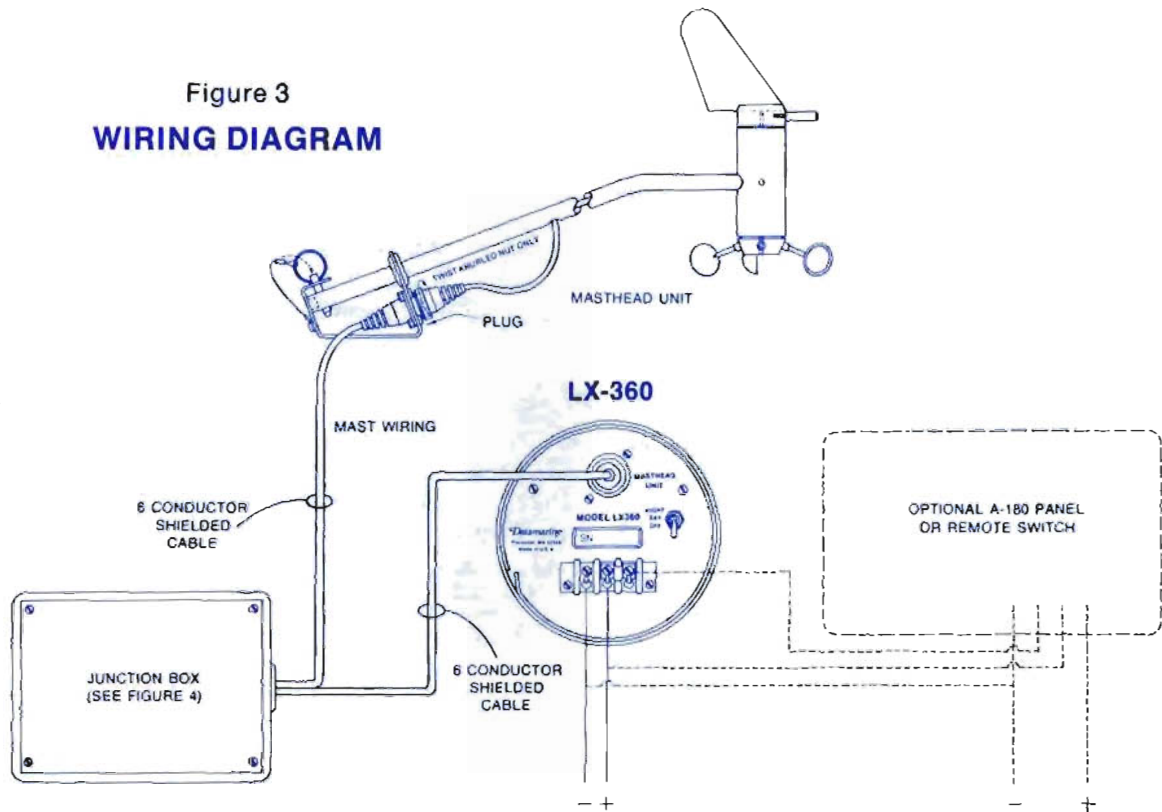

Figure 3
WIRING DIAGRAM

12



MOUNTING THE MASTHEAD BRACKET AND WIRING

Prior to stepping the mast, lay out the cable and masthead mounting bracket to determine the length of the cable needed. Cable length should allow for running to a convenient, dry location for the junction box once the mast is stepped. Once the necessary cable length is determined (to run to the mast step junction box), it should be cut and fed down the mast from the masthead.

The bracket should be mounted so the grommeted hole and the rear alignment pin line up with the fore/aft axis of the boat, the grommeted hole being forward. A mounting template is provided in the back of this manual. The bracket may be moved slightly within the confines of the adjustment slot for final positioning.

The LX-360's lower unit may be field adjusted to compensate for any masthead

mounting angle. The mounting bracket should be mounted horizontally (shim as needed) as close to the top of the mast as possible. An "L" shaped adapter bracket is provided for mounting on the side of a mast if this is needed.

The remaining section of cable should be installed from the final location of the LX-360 and run to the estimated location of the wiring junction box. Cable length is not critical and may be added to or trimmed as necessary.

If needed on a particular installation, Datamarine can provide a cable connector to use in place of the junction box. Wire color and pin connections are provided below.

<u>Pin #</u>	<u>Color</u>	<u>Pin #</u>	<u>Color</u>
1	White	5	Blue
2	Red	6	Yellow
3	Green	7	Shield
4	Black	8	Not connected

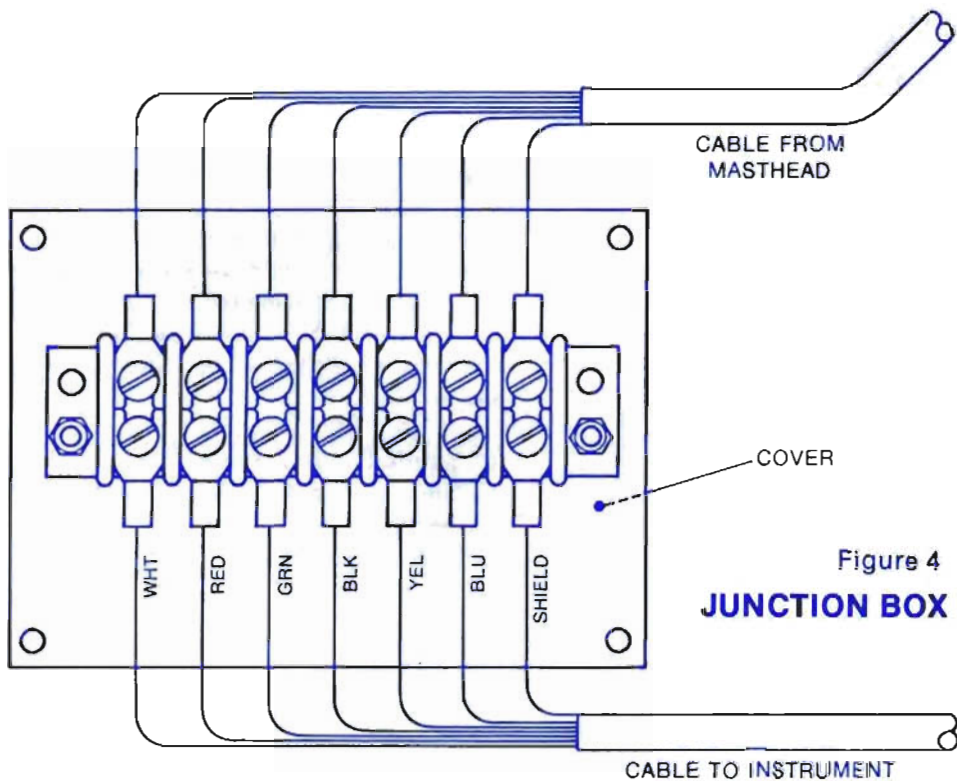

Figure 4
JUNCTION BOX DETAIL

Mount the junction box in a dry, convenient location and, once the mast is stepped, run both cut ends of the wire into it. Install the spade lugs provided and connect to the terminal strip (red to red, white to white, etc.) as shown on figure 4.

This completes the installation of the wiring required to connect the masthead unit to the LX-360. When the instrument and the masthead unit are installed, a simple plug-in is all that is required (plus a power connection to the instrument) to complete the installation.

NOTE:

Make sure *all* wires (especially the shield) are connected in the Junction Box. This will assure proper operation of your LX-360.

INSTALLATION OF MASTHEAD UNIT

The masthead boom (rotating cups and wind vane) is designed to mount in the masthead mounting bracket (see previous section). The boom should be slid into the grommets hole until it seats firmly over the rear alignment pin (see figure 5). At this point the boom retaining pin should be inserted to its full extent. Make sure the wind cups are on the bottom end of wind sensor housing when the boom is mounted.

The masthead cable connector should now be plugged into the receptacle on the mounting bracket. The connector should snap into place when seated properly and will provide a waterproof connection without the use of any sealants. The cable is designed to provide a drip loop, but this loop must not interfere with any other masthead hardware (spinnaker halyards, blocks, etc).

The masthead installation is now complete and ready for operation.

Figure 5
**INSTALLATION OF
MASTHEAD UNIT**

16

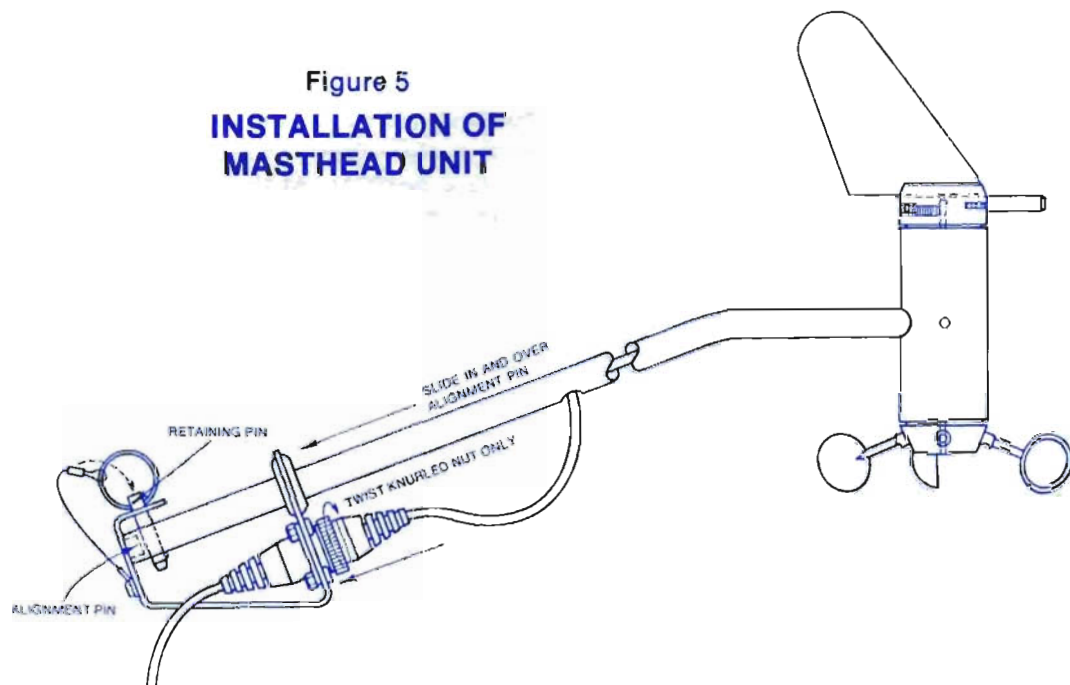

INSTRUMENT ALIGNMENT

With LX-360 turned on, one can adjust the lower indicating unit to compensate for any misalignment of the masthead sender.

A person at the top of the mast should first align the wind vane by hand so it points exactly forward; this can also be done by securing the wind vane with tape before the mast is stepped. After this is done, remove the instrument from its housing (spring retaining ring located on back panel edge) and locate syncro locking screw (see figure 6). Loosen this screw slightly and rotate the syncro until the pointer lines up at the zero mark. Retighten the locking screw snugly and reinstall the instrument in the housing. (*Do not over tighten locking screw*) This completes the alignment process. Be sure to remove any tape used to secure the wind vane when alignment is completed.

Operation of wind direction sensor and/or masthead functions, may be checked at any time by removing the masthead boom and connecting its cable directly to the rear of the LX-360.

REPEATERS

Provisions have been made for the use of one additional LX-360 instrument as a remote display. This second instrument must be ordered as a remote from the factory. Directional and speed accuracy will not be affected by this addition, although the second unit's directional alignment must be matched to the master at the time of installation.

To use a repeater with an LX-360 system, mast wiring must be paralleled from the junction box to the remote. In addition, 12 volt power wires must also be connected to the repeater (see figure 7).

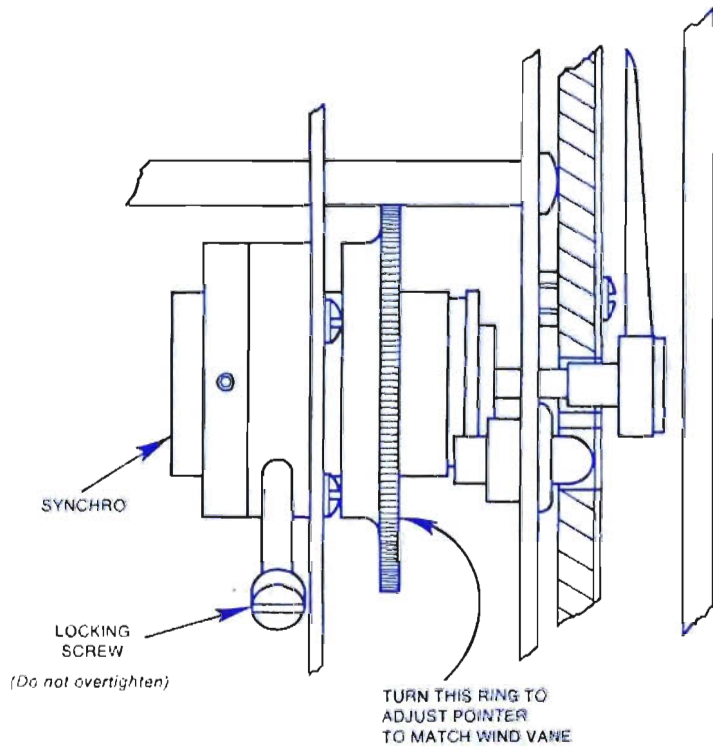
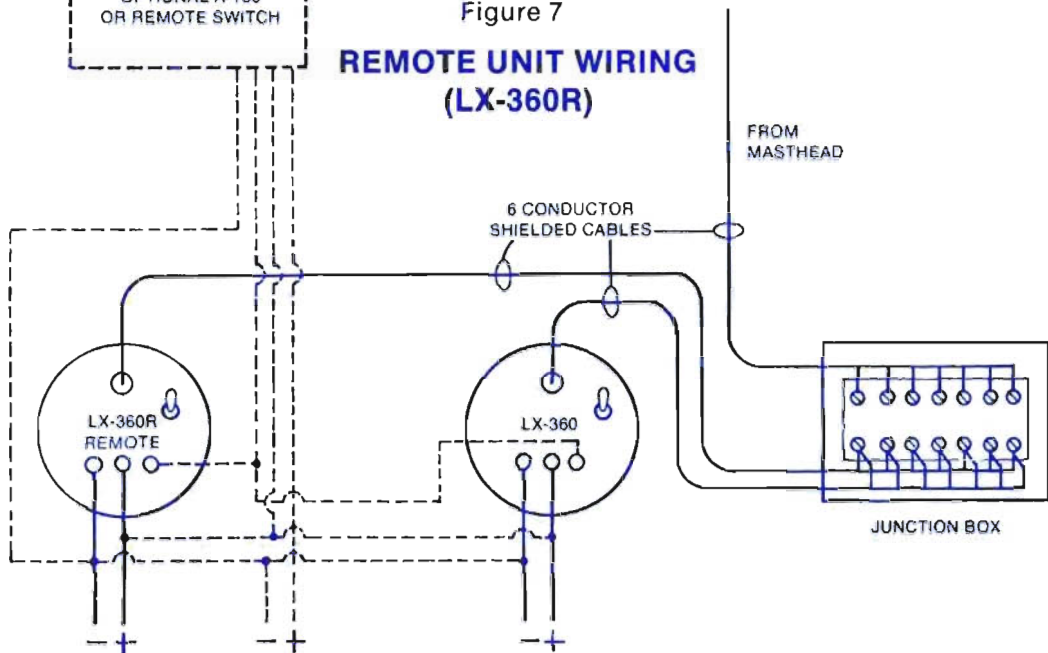

Figure 6
**HOW TO ADJUST
THE LX-360**

OPTIONAL A-180
OR REMOTE SWITCH

Figure 7

REMOTE UNIT WIRING (LX-360R)



MASTHEAD REPAIRS OR REPLACEMENT

Damaged wind cups or direction vanes may be simply replaced without the need of returning the masthead assembly to Datamarine.

Both the wind cups and the wind vane may be removed by loosening the small set screw in the side of each assembly and sliding the cups or vane off of the shaft.

- 20 To reinstall a wind vane, the vane should be slipped over the syncro shaft until it bottoms. (See figure 8) Care should be taken to install the new vane in the approximate position that the old one came off; this will help at the time of realignment. After installation of the new vane, the LX-360's direction syncro must be realigned (see section entitled "Instrument Realignment").

To reinstall a new wind cup assembly, line up for the set screw with the flat portion of the shaft and slide the assembly on the shaft until

the shaft is flush with the bottom of the wind cup hub. (See figure 8) Tighten the set screw securely. Please note: Individual wind cups are not replaceable, the whole unit must be changed.

After changing the cups or the vane, the masthead unit should be reinstalled as directed in the section entitled "Installation of Masthead Unit."

TROUBLESHOOTING

If your wind system is not operating properly, the following items should be checked before returning the LX-360 to the factory.

1. Check mast step junction box (or connector) for correct wiring.
2. Hook the masthead unit up directly to the back of the LX-360 instrument (bypassing the mast wiring). If the unit functions properly, the problem is probably with mast wiring.

Figure 8
**REPLACING COMPONENTS
ON MASTHEAD UNIT**

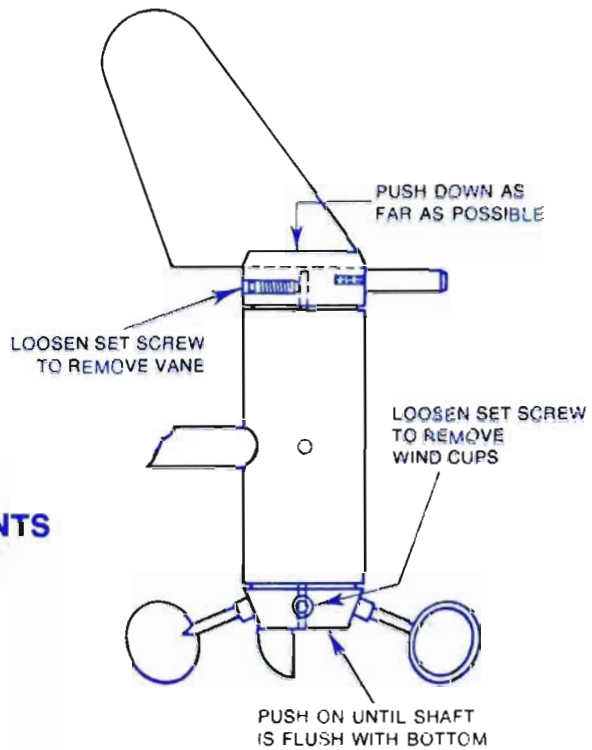

3. With the masthead unit connected, and the lower instrument disconnected, the following resistances may be checked (with an ohmmeter) at the instrument's power cable connector or at junction box.

The masthead unit would appear as follows to a D.C. meter.

Masthead Unit

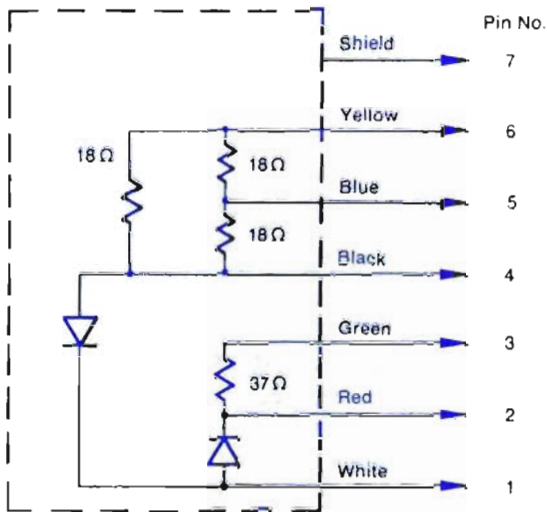

22

PIN	RESISTANCE ($\pm 10\%$)	COMMENTS
1 to 2 } 1 to 4 }	Approximately half scale on $1 \times$ scale, (∞ if leads are reversed)	Due to (2) diodes in transmitter
3 to 2	$39\ \Omega$	Transmitter rotor
4 to 5	$14\ \Omega$	Transmitter stator
5 to 6	$14\ \Omega$	Transmitter stator
7 to any pin	∞	7=shield
8	Not used	—

If there is an apparent short or open circuit, the LX-360 system will not work. One should try to isolate the portion of the system where the problem is and correct it before damage to the instrument occurs.

SPECIAL INSTRUCTIONS FOR REMOTE MOUNTING OF POWER SWITCH

Owners of S-200DL, S-100KL, and LX-360 instruments may remotely mount a power/night light switch for control of the instruments when rear panel access is restricted (i.e. pod mounts, etc.).

Datamarine's A-180 control panel/log is ideally suited for this application when the S-100KL is included in the installation. The A-180 provides both an ON-OFF switch with

a night lighting brightness control and a non-resettable log.

A double pole — double throw switch may be used for this remote control. A wiring diagram is provided below to aid in connecting a switch of this type.

The power switch on the back of the instrument must be left in the "NIGHT" position when using a remote switch. Also, the jumper between the "+12" terminal and the "lamp" terminal must be removed to use a remote switch.

23

ONE OR MORE
LCD INSTRUMENTS

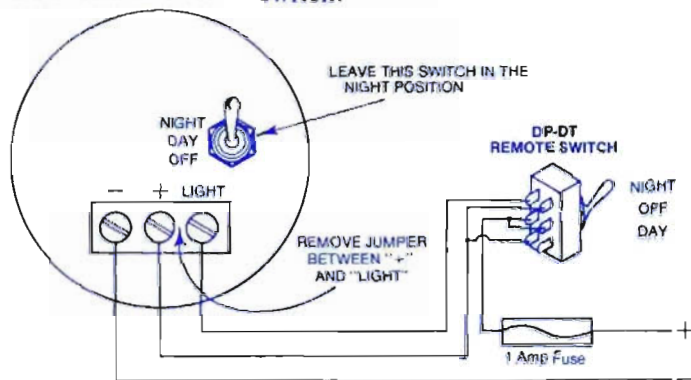

WARRANTY CONSIDERATIONS:

At the time of purchase, be sure that the warranty card for your LX-360 is properly filled out and returned to the factory for proper warranty registration

PLEASE NOTE

24 WARRANTY WILL BE VOIDED BY:

- * IMPROPER FUSES
- * OVERVOLTAGE DAMAGE
- * PHYSICAL DAMAGE
- * SALTWATER IMMERSION
- * IMPROPER ATTEMPTS AT REPAIR
- * OPERATION OR STORAGE AT TEMPERATURES BEYOND THOSE SPECIFIED

INSTRUMENT SERVICE:

FOR PROMPT FACTORY SERVICE,
MAIL OR SHIP TO:

Datamarine International, Inc.
Service Department
53 Portside Drive
Pocasset, MA 02559 USA
Telephone: (617) 563-7151

(Include return address, symptoms, and installation factors). REPAIRS OUT OF WARRANTY WILL BE PERFORMED AT MODEST COST FOR LABOR AND PARTS. THE INSTRUMENT WILL BE RETURNED TO ADDRESS SPECIFIED WITH A C.O.D. CHARGE FOR SERVICE AND FREIGHT. Please refer to complete Warranty Statement and Service Program, enclosed with product shipment.

**MOUNTING TEMPLATE FOR
MASTHEAD BRACKET**

CUT ON DOTTED LINE



25

DRILL AND TAP HOLES AS REQUIRED

Warranty

All Datamarine products are covered by a 12 month limited warranty and a subsequent four year service program. Please refer to the complete warranty statement or consult your servicing Datamarine dealer. Please be sure to complete and return the warranty registration card at the time of purchase.

Datamarine[®]

Precision Marine Instruments

Datamarine International Inc., 53 Portside Drive, Pocasset, Mass. U.S.A. 02559

LX 360

WIND MACHINE

PACKING LIST:

1. Instrument with retaining collar
2. A-176 mast wiring with masthead mounting bracket
3. Installation hardware and side mounting bracket
4. A-175 masthead wind speed/wind direction sensor with vane and wind cups
5. Wiring junction box with terminals
6. 6' power cord with 1 amp fuse
7. A-170 protective cover
8. Set screw kit
9. Instruction manual and warranty card
10. Limited warranty and four year warranty sheets

DATAMARINE INTERNATIONAL, INC.

53 Portside Drive

Pocasset, MA. 02559 USA